



# STERIVAP® SL

Compact and Economic Steam Sterilizer  
for Health Industry



protecting human health

## MMM Group – Leading Service Provider in Health Industry

Skupi Since 1954, the MMM Group has globally acted as one of the leading system suppliers of products in health service.

Thanks to its complex offer of products and services, sterilization and disinfection equipment for hospitals, scientific institutions, labs and pharmaceutical industry, the MMM group established as an excellent quality and innovation provider in German and international markets.

BMT Medical Technology s.r.o. is an active member of the MMM Group with many years of tradition in manufacture of steam sterilizers. Our production plant in Brno manufactures devices and central sterilization equipment based on requirements of our clients all over the world. We provide wide range of production while meeting highly demanding requirements towards quality in the medical engineering field.

### Optimised Price/Utility Value Ratio

Steam sterilizer STERIVAP® SL represents an ideal option for everyday use in health industry.



STERIVAP® SL is the right option for small health care units as well as for small central sterilization units, putting stress on small ground dimensions of the device and favourable price/utility value ratio. Top production quality, modern electronics and high quality materials of the device STERIVAP® SL are as natural as the utility characteristics and exceptional safety and reliability level. The steam sterilizer STERIVAP® SL is designed for sterilization of solid, porous and cavity materials designed for steam sterilization with min. temperature of 121°C and solutions in open bottles. The basic version of the device with useful volume of 160–885 litres plus optional equipment offer will satisfy those interested in high-quality sterilization.

### Technical and Legislative Standards

The device meets all and any European standards applicable to large steam sterilizers, mainly the standard EN 285.

For this purpose, the company BMT Medical Technology s.r.o. holds certification of the full quality management system according to the following regulations:

- standard EN ISO 13485 and European regulation No. 93/42/EEC for health care means.
- standard EN ISO 9001 for products and together with European regulation No. 2014/68/EU, module H/H 1 for pressure devices.
- standard EN ISO 14001, environmental management certificate.

The accredited Testing Laboratory No. 1325 operates at BMT Medical Technology s.r.o.

MMM Group – Perfection in Health Care Engineering



### Unique Thanks to the Thin Design

#### When Buying the STERIVAP® SL Steam Sterilizer Line, You Get:

- large-volume steam sterilizer with small ground plan, saving space in your central sterilization department
- possibility of devices placement next to each other without necessity of service space
- advantage of service access to the device from the front side of the device
- sterilizer with built-in steam generator and device for cooling water economy, providing operation costs reduction
- possibility of intuitive device control at the loading and unloading side using the touch panel 8.2"
- device with easy assemblage and easy service including auto-diagnostics



## New Structural Design

- front-side service (no side service space needed)
- robust pressure sterilization chamber with heated shell, the door and built-in steam generator made of high-quality stainless steel – used materials: AISI 316 Ti and AISI 316 L
- down-take bottom of the sterilization chamber for perfect drying
- ground inner surface of the sterilization chamber, coarseness Ra 1,25 µm (Ra 50 µinch)
- heat insulation of the sterilization chamber using a special insulation layer of Isover with thickness of 100 mm.
- as a standard, all the sterilization chambers are equipped with two easily accessible inlet necks with diameter of 25 a 50 mm in compliance with EN 285
- robust stainless steel frame with max. width of 1000 mm
- all the tube distribution units are heat insulated
- The powerful and low-noise two-stage vacuum pump provides fast air-removal from the chamber, thus reducing the cycle times. A special water saving system helps recunding water consump
- simple mechanic filter at the feeding water input for valve and membrane protection
- bacteriological filter for sterilization chamber aeration (0.1 µm)
- integrated drain – so as to eliminate humidity in the device area, all the pipes lead to a common tank
- one-door and two-door (interleaving) version (vertically movable doors), stainless steel sheeting of the device – compared to usual solutions, they are strengthened with a frame that extends the service life
- access to the device – provided by lockable door panels

## Intelligent System of Media Saving

- built-in device for water saving for the membrane, reducing operation costs in as much as 15%
- steam generator with microprocessor automatics and unique construction with automatic desalination provide high quality steam
- the function "Automatic morning switch on" represents another saving product to save your work time. The device starts in pre-set time without staff presence, it is automatically pre-heated and the vacuum test is performed.

## New Design

- robust construction with long service life
- unique system of door balancing
- components from best global manufacturers
- two-processor system Master & Slave for maximally safe sterilization process
- doubled safety elements
- light bar with indication of operation status of the device

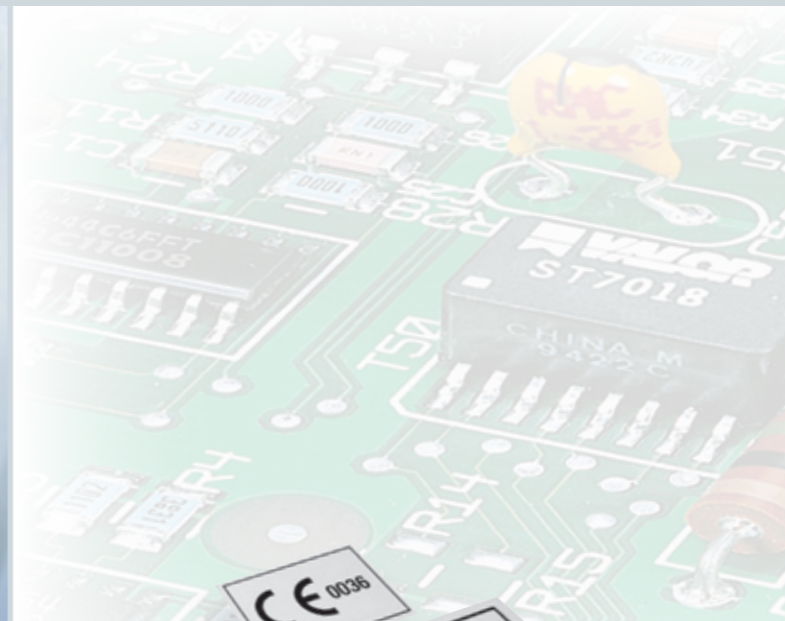
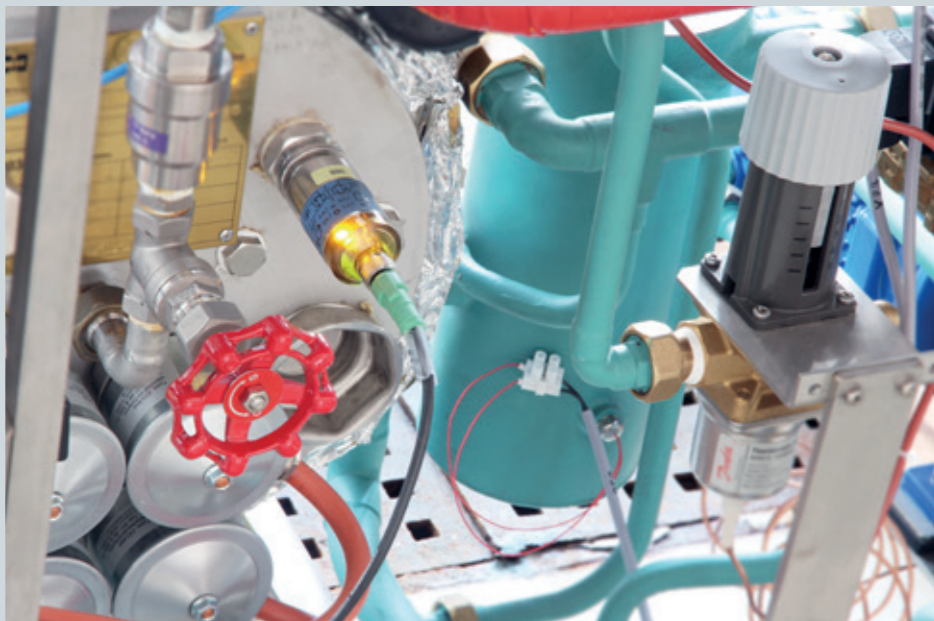

- motive-power control of sterilization chamber door with a unique spring mechanism, with double safety door protection (safety lath and connection)
- standard built-in steam generator is made of stainless steel as well as the heating bodies
- tube distribution system bringing steam to the sterilization chamber – as a standard it is made of stainless steel, the valves are stainless steel
- reinforced stainless steel sheeting for quiet operation





## New Control Panel with Intuitive Control

- two built-in microprocessor PLC control systems (Master-Slave) with own sensors for independent assessment, sequencing and documentation of operation cycles
- ergonomically located control panel
- touch display technology "touch-screen" 8.2" provides well-arranged and simple service on charging side
- "touch-screen" 5" on discharging side (in case of the two-door version)
- "Emergency stop" function integrated in the control panel
- built-in printer for documentation of sterilisation processes
- USB connector on front side for easy transfer of data, programs, protocols, device configuration, etc...
- possibility of language selection for communication with the device
- well-organised digital displaying of pressure and temperature in the sterilization chamber (reference bottle), steam pressure in the sterilization chamber shell and in steam generator
- hours – indicator of remaining program time and real time indicator
- protocols history – integrated memory allows saving of as many and tens of thousands protocols (in graphic or numeric form)
- history of faults – the function allows displaying of error messages on the display

- additional comments – the device allows for the staff to write additional comments to individual programs, resp. cycles (e.g. product name, batch number, series number, etc.) to be included in the record from the printer as well.
- logging – access rights allowing setup of user rights for use of the device
- visual and acoustic signalling of status and processes
- it allows selection of preferred pressure and temperature units
- automatic start programming function
- possibility of automatic door opening after the cycle finishing

## We Offer 50 Program Spots in Basic Program Equipment

As a standard, the device is equipped with "Pre-heating Program" (134°C/1min)

### Standard Programs:

- Unpacked tools 134°C/4 min
- Packed tools 134°C/7 min
- Packed materials with intensive additional drying 134°C/7 min
- Packed products of glass, rubber and plastics 121°C/20 min

## Special Programs with Parameters According to Client's Specification:

- Prions 134°C/60 min
- Disinfection 105°C/20 min
- Solution in open bottles 121°C/20 min, spontaneous cooling
- "Arnold" 100°C
- Laparo, allo-plastics, optics...
- Extremely long cavities
- Other special programs

Programs according to specific requirements must be validated at the client! Maximal safety during sterilisation of solutions – together with standard operation and safety procedures and processes, the solutions sterilization is checked by three independent systems – temperature and pressure control in sterilisation chamber, temperature in reference bottle and minimal necessary time of the sterilization cycle. Only based on fulfilment of all and any above stated processes the program is assessed as finished and the system allows for the chamber door to be open.

### Standard Testing Programs for Routine Control:

- Vacuum test – test of chamber air-tightness, balancing phase duration 5 min, test length 10 min
- Bowie&Dick test 134 – test of steam penetration, 134°C/3.5 min

## Service Equipment

The PLC automatics of the device is equipped with extensive software for easy control, maintenance and testing (interactive schemes of tube connections, testing programs allowing testing of safety elements of the device, calibration settings, etc.). The program equipment can be changed via the USB port, service software UNICONFIG. The program data values may be modified directly from the touch display. The device allows detailed planning of service operations with consequent warning on the display or on printer report. The USB port is designed for transfer of data, programs, export of protocols, device configuration, Audit trail, etc.

## Batches Documentation

- independent documentation of operation cycles with recording of pressure and temperature and many other parameters with the possibility of protocols saving in the sterilizer memory.
- connection to PC and protocols saving in the computer memory using the "PrinterArchiv" software
- sterilizer connection to computer network (LAN) together with software application Ecosoft and DP 3.5
- built-in printer with the possibility of selection of one or two graphic outputs
- possibility of direct connection of an external printer (selected types) via USB, LAN.

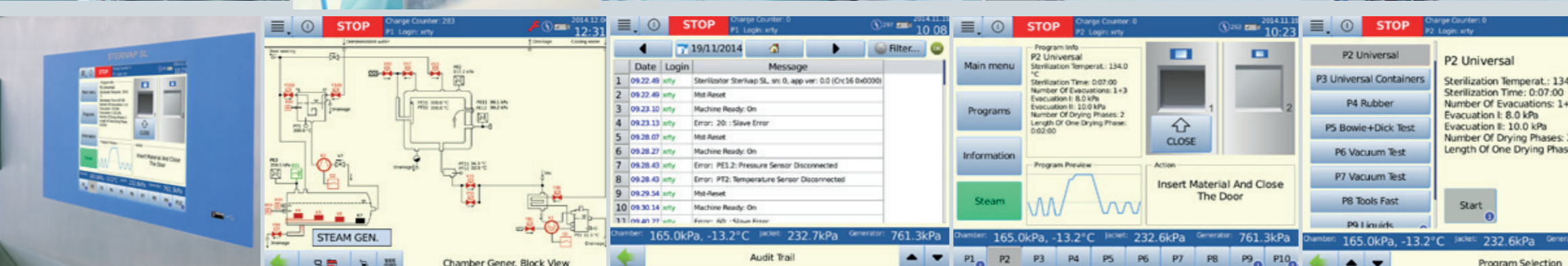



## Modular System

- 1 system for manual charging
  - a) shelves guides
  - b) perforated shelf
- 2 system of transport and charging carts
  - a) frame for charging cart
  - b) charging cart
    - 1) universal
    - 2) special
    - 3) solution
  - c) transport and charging cart,
  - d) drip tube for solutions,
  - e) hook for removal of charging carts
- stainless steel facing sheets of the device
- 3 stainless steel valves
- possibility of building-in in stainless steel partition walls
- printing the graphic recording of pressure and temperature on a built-in printer for the sterilization cycle documentation

## Optional Equipment

- 4 thermal degasification of feeding demi water so as to minimise the contents of non-condensable gases in steam generator
- 5 possibility of building-in a device for additional condensate cooling
- 6 "Air detector" for continuous control of air and non-condensable gases presence in the sterilization chamber in the course of each sterilization program for maximal safety of sterilization compared to routine checks using testing programs (Vacuum and Bowie&Dick test) performed only once per day before ordinary operation start (HTM 2010)
- special programs applicable to the device in a simple way, using the Flash disc (USB) and using the USB port of the device.
- 7 additional mechanical manometers
  - a) on loading side
  - b) on unloading side
- tropical version for countries with high temperature of cooling water
- continuous control of input media parameters (pressure air, demi and cooling water)
- "Audit trail" – systems events recording on a memory card (conforms with 21CFR part 11)
- Device anchoring for seismic-active areas

## Chamber Use

- 8 sterilization basket
- 9 variability of containers line use
- 10 solutions sterilization – reference bottle with temperature sensor PT 100

**Sterivap SL 5016833**

P2 Warm up, 134.0° (PT1.2), 0:02:00  
 User: xrtj  
 Start 16:57:37 2014-10-02  
 T(PT2) = 51.5 °C; p = 99.0 kPa

**Charge 00251**

Evacuation (0)  
 T(PT2) = 51.1 °C; p = 99.5 kPa; 16:57:52 2014-10-02

Preheating (3) 17:00:43 2014-10-02  
 T(PT2) = 84.2 °C; p = 9.1 kPa

Heating 17:00:44 2014-10-02  
 T(PT2) = 84.2 °C; p = 9.1 kPa

Exposition 17:03:15 2014-10-02  
 T(PT2) = 129.9 °C; p = 270.8 kPa

Start Of Sterilization 17:04:04 2014-10-02  
 T(PT2) = 134.3 °C; p = 313.7 kPa

End Of Sterilization 17:06:04 2014-10-02  
 T(PT2) = 135.1 °C; p = 310.7 kPa

Aeration 17:11:37 2014-10-02  
 T(PT2) = 44.2 °C; p = 90.2 kPa

End 17:11:47 2014-10-02  
 Program Length = 00:14:10

**Cycle Passed**

User: xrtj  
 Signature:

Time: Phase: Temperature(°C): Pressure(kPa):

Graph showing Temperature (°C) and Pressure (kPa) vs Time (min) for the cycle.

## Construction Variability

The double-door device construction allows various height designs for the clean side built-in.

### In-wall variant, lower

A hole in the wall with the size of 1900x1100 mm.

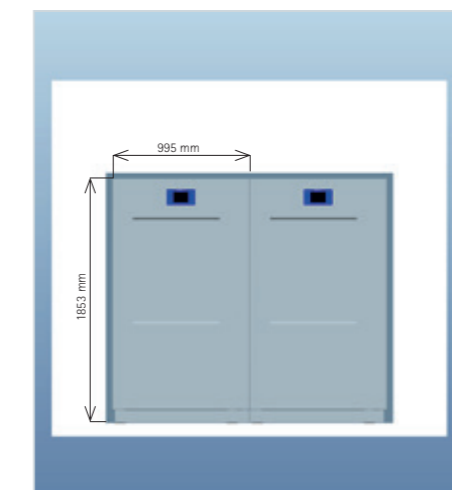
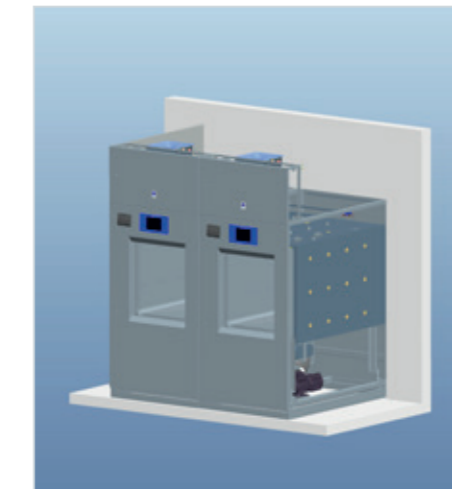
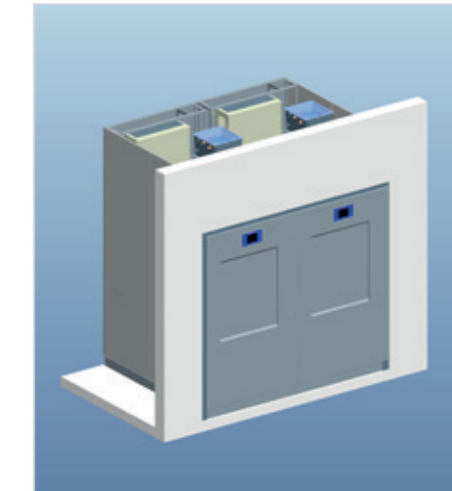

### In-wall variant with top sheeting

A hole in the wall with the size of 2450x1100 mm.

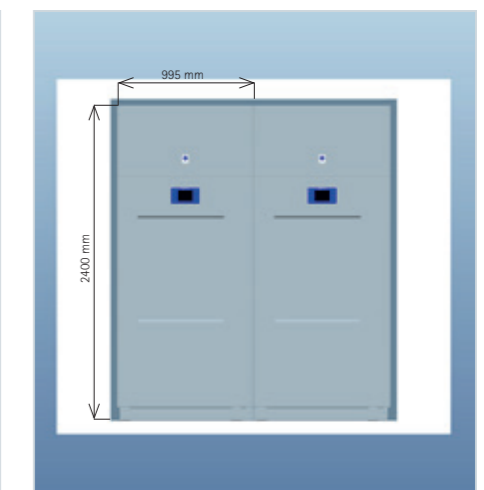
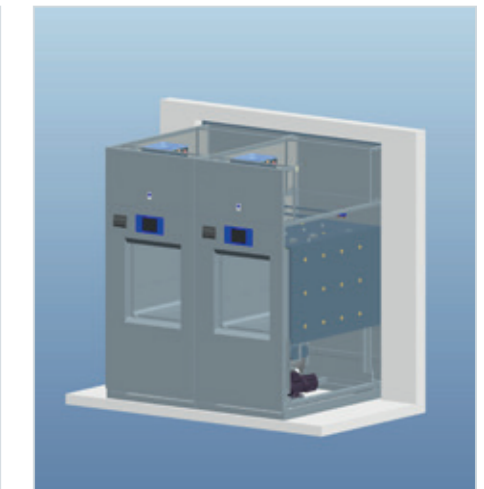
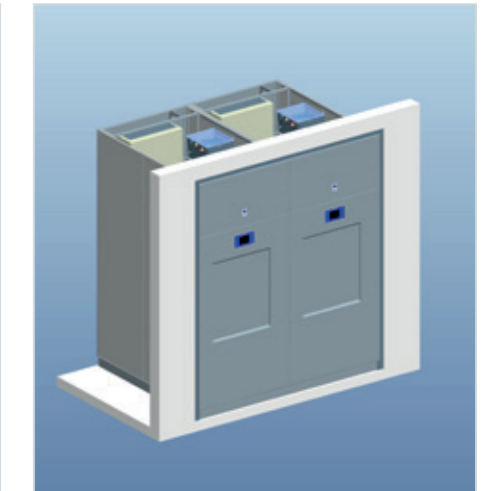



## Client Service Arrangement

Together with standard supplies of instrumentation, we offer a wide spectrum of services connected with development of central and chart room sterilization units.

- consultancy and project processing including logistics and capacity calculations
- supply of instrumentation including individual information systems "on turn key"

User support and service are arranged in full by the global network of contractual organisation of BMT Medical Technology s.r.o. We have an extensive network of brand service units connected to HOT-LINE service and providing prompt reaction to clients' questions and requirements. A special auto-diagnostic program has been developed for user's comfort and possibility of fast and high-quality service intervention.

We offer ON-LINE internet diagnostics and sterilization device monitoring (RMS) providing fast and direct communication with the instrumentation and arranging fluent and trouble-free operation of the work site.

All these features guarantee low costs and long service life of the device.

## Validation

We offer performance of IQ and OQ validation tests to our clients on installation site and we also co-operate in arrangement of PQ and requalification tests. The tests are performed by our Accredited Laboratory No. 1325 in compliance with EN ISO 17665-1 and approved operation procedures.

## Environmental Awareness

The device meets all and any current environmental requirements. It does not burden the work and living environment. The external insulation shell of the sterilization chamber is equipped with high-quality insulation significantly reducing thermal losses and saving electric power. The two-level quiet membrane with feeding water saving device built-in as a standard saves approximately 15% of operation costs. The unique construction of steam generator with automatic desalination provides short sterilization cycle times and stable high quality of steam.

High quality materials guaranteeing long service life of the device are used in manufacture. The device can be optionally equipped with a device for additional cooling of waste water allowing waste temperature setting. The device does not produce any harmful waste. Even its factory manufacture process is based on environment friendly methods of processing. All the significant parts of the device and package are recyclable. The device consists of 95% of steel, 4% of other materials, 1% of electric material and plastics. Environment – friendly liquidation is performed after dismantling by an authorised person in compliance with EU regulations, corresponding with the WEEE regulation (Waste Electric and Electronic Equipment).

# STERIVAP®<sub>SL</sub> – Technical Parametres



Model SP SL	Dimensions (h×w×d) [mm]		Number of steri. units [STJ]	Chamber volume [l]	Weight [kg]	Cca max. input [kW]/ fuses [A]	cca max. consumption per 1 steril. cycle		
	Internal – chambers	External – device					Water [m³]	Demi-water [m³]	El. power [kWh]
559 – 1	508×508×990	2200×895×1270	1	254	850	24,5/40	0,07	0,008	6
559 – 2	508×508×990	2200×895×1290	1	254	880	24,5/40	0,07	0,008	6
636 – 1	670×350×700	2400×795×970	2	160	690	17/25	0,06	0,006	5
636 – 2	670×350×700	2400×795×990	2	160	720	17/25	0,06	0,006	5
666 – 1	702×652×690	2400×995×970	4	314	800	24,5/40	0,07	0,008	6
666 – 2	702×652×690	2400×995×990	4	314	840	24,5/40	0,07	0,008	6
669 – 1	702×652×990	2400×995×1270	6	453	900	38/63	0,08	0,009	7,5
669 – 2	702×652×990	2400×995×1290	6	453	940	38/63	0,08	0,009	7,5
6612 – 1	702×652×1340	2400×995×1620	8	610	980	48/80	0,09	0,011	9
6612 – 2	702×652×1340	2400×995×1640	8	610	1020	48/80	0,09	0,011	9
6618 – 1	702×652×1940	2400×995×2220	12	885	1220	57/85	0,16	0,013	15
6618 – 2	702×652×1940	2400×995×2240	12	885	1260	57/85	0,16	0,013	15

Model xxx-1 – one-door design, Model xxx-2 – double-door design  
 Connection voltage 3 NPE AC 400V 50/60Hz  
 Max. noise level 78 dB  
 Transport height of the machine is 1900 mm



The values may differ depending on specific charge and media parameters. Construction and design changes reserved.

The model line STERIVAP® offers optimal solution for your individual requirements.



Engineering serving a man – simple, economic and safe.

STERIVAP®  
 – high utility value for reasonable price

STERIVAP®<sub>HP</sub>  
 – more individuality and comfort





More information  
is available direct from  
our internet web site

[www.bmt.cz](http://www.bmt.cz)

Make acquaintance with our further offers...



Small steam sterilizers 15-25 l



Steam sterilizer 70 l



Laboratory drying devices and incubators 22-1212 l

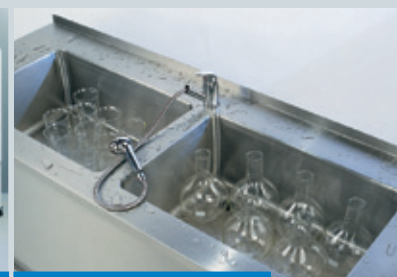

Stainless steel instrumentation



Formaldehyde sterilizer 110 l



Exchanger steam/steam



Washer disinfectors for medical usage 200-500 l



Washer disinfectors for medical usage 171 l



[youtube.com/bmtbrno](https://www.youtube.com/bmtbrno)



[facebook.com/bmt.cz](https://www.facebook.com/bmt.cz)



BMT Medical Technology s.r.o., Cejl 157/50, Zábřovice, CZ 602 00 Brno  
Tel.: +420 545 537 111, fax: +420 545 211 750, e-mail: [mail@bmt.cz](mailto:mail@bmt.cz), [www.bmt.cz](http://www.bmt.cz)

